



**Art 176X1: Paper waste basket with swing lid**  
**Art 176X1: Cestino gettacarta con coperchio basculante**  
**Technical product sheet**  
**Scheda tecnica prodotto**

Art:176X1



Capacity: 12 liters.  
Frame: AISI 304 (18/10) polished.  
Equipped with non-slip rubber feet.

Quantity per pack: 1

Capacità: 12 litri.  
Struttura: acciaio inossidabile AISI 304 (18/10)  
lucido.  
Piedini di appoggio in gomma .

Pezzi per cartone: 1

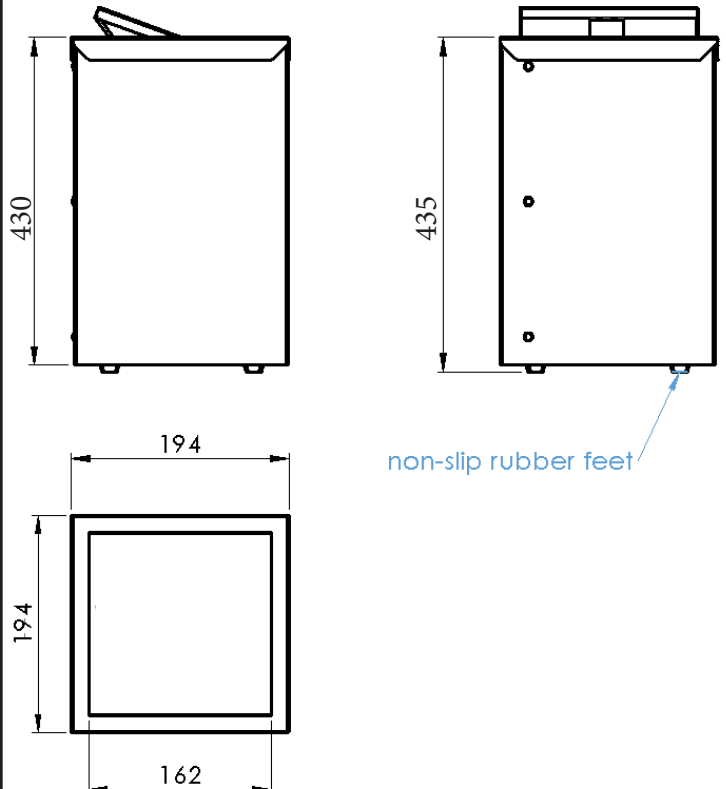

Article	net weight	gross weight	pack. dimensions	EAN
A176X1	KG 3,8	KG 4,5	21x21x43,5 cm	8058269250133